

# Basic UV/Visible Spectrophotometry

## CONTENTS

<b>1. INTRODUCTION</b>	<b>2</b>
<b>2. THE ELECTROMAGNETIC SPECTRUM</b>	<b>3</b>
<b>3. RADIATION AND THE ATOM</b>	<b>4</b>
<b>4. RADIATION AND THE MOLECULE</b>	<b>5</b>
Electronic Transitions	5
Vibration and Rotation	6
<b>5. SPECIFIC ABSORPTION</b>	<b>7</b>
<b>6. ABSORPTION AND CONCENTRATION</b>	<b>8</b>
<b>7. INSTRUMENTATION</b>	<b>11</b>
Source	11
Monochromator	11
Filters	12
Prisms	12
Diffraction Gratings	13
Optical geometry	14
Single beam optics	14
Split (reference) beam optics	14
Double beam optics	15
Diode array optics	15
Sample handling	16
Detectors	17
Photomultiplier	17
Silicon diode	17
Diode array	17
Measuring Systems	18
<b>8. GOOD OPERATING PRACTICE</b>	<b>19</b>
Preferred absorption range	19
Absorbance Measurement	19
Solvent selection	19
<b>9. SOURCES OF ERROR</b>	<b>20</b>
Instrument related sources of error	20
Spectral bandwidth and slit width	20
Stray Light	21
Absorbance Accuracy	21
Wavelength Accuracy	21
Noise	21
Non-instrument sources of error	22
<b>10. EXPERIMENTS</b>	<b>23</b>
EXPERIMENT 1 - Calculation of absorbance at $\lambda$ max, and measurement of natural bandwidth.	24
EXPERIMENT 2 - Construction of concentration plots	24
EXPERIMENT 3 - Testing for Stray Light	25
EXPERIMENT 4 - Demonstration of visible colours and spectral sensitivity of the human eye.	25

# 1. Introduction

The spectrophotometer has well been called the workhorse of the modern laboratory. In particular, ultraviolet and visible spectrophotometry is the method of choice in most laboratories concerned with the identification and measurement of organic and inorganic compounds in a wide range of products and processes - in nucleic acids and proteins, foodstuffs, pharmaceuticals and fertilisers, in mineral oils and in paint. In every branch of molecular biology, medicine and the life sciences, the spectrophotometer is an essential aid to both research and routine control.

Modern spectrophotometers are quick, accurate and reliable and make only small demands on the time and skills of the operator. However, the user who wants to optimise the functions of his instrument and to be able to monitor its performance in critical areas will need to understand the elementary physics of the absorption process as well as the basic elements of spectrophotometer design.

This booklet sets out to present that background for both the student and the scientist, primarily neither chemist nor physicist, whose subject makes use of analytical procedures and who may want to know more than the basic outline. The molecular biologist, biochemist, geologist or the pathologist, the pharmacist or the metallurgist - almost any scientist whose discipline involves materials analysis - may feel more secure in his or her mastery of the mechanics of UV/Vis absorption spectrophotometry with this introduction to the underlying principles. He may, for example, prefer to make his own judgements about trade-offs in limiting conditions, and reference to the experiments at the end of the booklet may assist in this.

## 2. The Electromagnetic Spectrum

Man lives in an environment that is permanently exposed to naturally occurring electromagnetic radiation, some of which he detects with his own senses. Radiant heat from the sun is recognised by the body as warmth while the eye responds to light to give the power of sight. But the visible spectrum, that part of the whole spread of wavelength to which the human eye is sensitive, is a very small part of the total range. The familiar rainbow colours extend in one direction beyond red through infrared to microwaves and radio waves (increasing wavelength) and in the other direction past violet to ultraviolet and then, with progressively diminishing wavelength, via X-rays and gamma rays to cosmic rays (Fig. 1).

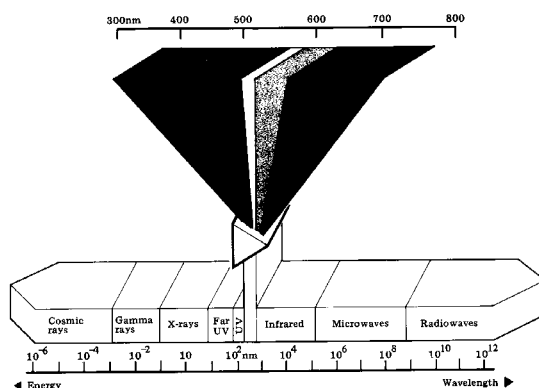

Fig. 1. The electromagnetic spectrum.

The spectrum is smoothly continuous and the labelling and assignment of separate ranges are largely a matter of convenience. It is important to note that all natural radiation is a form of energy and that energy is inversely proportional to wavelength: the shorter the wavelength the higher the energy.

All electromagnetic radiation travels at a fixed speed of  $3 \times 10^{10}$  cm per sec which is the speed of light,  $c$ , in a vacuum. The distance between two peaks along the line of travel is the wavelength,  $\lambda$ , and the number of peaks passing a point in unit time is the frequency,  $\nu$ , usually expressed in cycles per second (hertz) (Fig. 2).

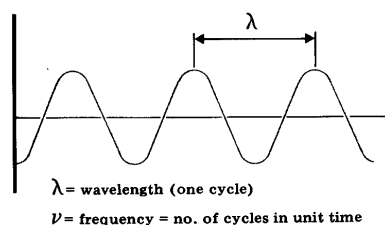

Fig. 2 Wavelength and frequency.

The arithmetic relationship of these three quantities is expressed by

$$c = \lambda \nu$$

The laws of quantum mechanics may be applied to photons to show that

$$E = h \nu$$

where  $E$  is the energy of the radiation,  $\nu$  is the frequency and  $h$  is Planck's constant.

Combining these two equations,

$$E = h c / \lambda$$

In the visible region it is convenient to define wavelength in nanometres (nm), that is in units of  $10^{-9}$  metres, although other units may be encountered such as millimicron ( $m\mu$ ) or Angstrom ( $\text{\AA}$ ).

$$1 \text{ nanometre} = 1 \text{ nm} = 1 \text{ m}\mu = 10 \text{ \AA}$$

The visible spectrum is usually considered to be 380 - 770 nm and the ultraviolet region is normally defined as 200 - 380 nm.

### 3. Radiation and the Atom

Although it is convenient to describe electromagnetic radiation in terms of waves, it is necessary to define another model in order to demonstrate clearly the interactions that lead to selective absorption by an atom or molecule. A determining factor is the energy level of the radiation and it is therefore helpful to consider radiation as discrete packages of energy, or quanta. A quantum of light is known as a photon.

The absorption process depends upon an atomic structure in which each of the electrons of an atom has an energy level associated with its position in the atom. Permitted energy levels are finite and well defined, but an electron may be made to change to another level if a quantum of energy is delivered equal to the energy difference between the two levels. The original level is called the ground state and the induced level is known as the excited state. Excited states are generally unstable and the electron will rapidly revert to the ground state, losing the acquired energy in the process.

Whilst the accepted model of atomic and molecular structure has arisen from the wave mechanical treatment of Schrodinger, it is convenient to employ an earlier model (that of Bohr) in order to explain more simply the electronic phenomena of interest in spectrophotometry.

The Bohr model defines an atom as having a number of electron shells, n1 - n2 - n3 etc, in which the increasing values of n represent higher energy levels and greater distance from the nucleus. Electrons rotate about the nucleus in orbits that may be characterised by the space they occupy and are designated s, p, d, etc according to their geometry. An atom may contain several electrons in multiple orbits in each shell (or each n level) but no orbit may contain more than two electrons (*Fig. 3*).

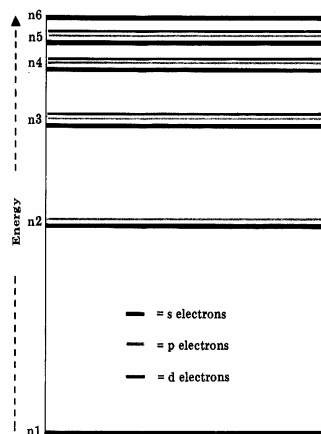

*Fig. 3 Diagrammatic presentation of simplified electron energy levels in an atom.*

No two electrons can have identical energies but all can be assigned to groups corresponding to the shells, each of which has a clearly differentiated energy level. The effect of subjecting an atom to appropriate radiation is well demonstrated by considering atoms of sodium vapour.

A sodium atom at ground state ( $\text{Na}_0$ ) will absorb a photon at 589 nm to cause a transition of an electron in the outermost shell to a higher energy orbital.

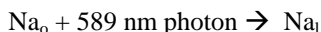

The same ground state atom will also absorb a 330 nm photon to promote a transition to its second excited state.

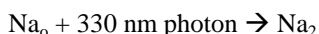

The diagram illustrates the higher energy required to cause a second level transition, corresponding with the higher energy (shorter wavelength) of the radiation that stimulates the transition (*Fig. 4*)

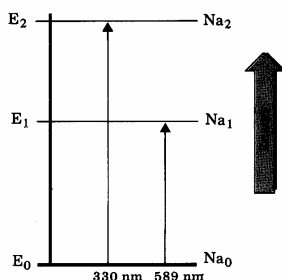

*Fig. 4 Absorption by gaseous atomic sodium*

## 4. Radiation and the Molecule

### Electronic Transitions

Electrons in the atom can be considered as occupying groups of roughly similar energy levels. In the more complicated molecular model, electrons associated with more than one nucleus, the so-called bonding electrons, are particularly susceptible to energy level transitions under the stimulus of appropriate radiation.

The electrons concerned, usually p type electrons in the first or second shell, may be present in one of two conditions:  $\sigma$  (sigma) in localised bonds with a low probability of transitions (and therefore of absorption) or  $\pi$  (pi) where the transition probability is much higher. The presence of a carbon-carbon double bond in the molecule increases the likelihood of  $\pi$  type bonds, especially when conjugated double bonds are involved, i.e. double bonds that alternate with single bonds. The effect is still greater in the presence of nitrogen.

Chemical bonds are formed by overlapping atomic orbitals that result in molecular orbitals of one of three types: bonding (low energy), antibonding (high energy), or non-bonding. Energy absorption is most typically associated with transitions induced in electrons involved in bonding orbitals, and the atoms involved are, for the most part, those containing s + p electrons. Two types of bond must be mentioned:

- (1)  $\sigma$  bond with its related antibonding orbital designated  $\sigma^*$  and
  - (2)  $\pi$  bonds with the corresponding  $\pi^*$  antibonding orbital.
- The uninvolved n (non-bonding) electrons have no antibonding orbital.

The full series of permitted electronic transitions (by UV/Vis absorption) is:

The figure shows that  $\sigma \rightarrow \sigma^*$  and  $n \rightarrow \sigma^*$  transitions require relatively high energy and are therefore associated with shorter wavelength radiation (ultraviolet). Lower energy  $n \rightarrow \pi^*$  and  $\pi \rightarrow \pi^*$  are ultraviolet or visible induced transitions.

The probability that transition (and therefore absorption) will occur is closely related to molecular orbital structure. If the configuration of the molecular orbitals is accurately known, the probability can be calculated with some certainty and an estimate can be made of the energy intensity (relative to other transitions), indicating an approximate value for the molar absorptivity of the species.

Whenever two double bonds are conjugated (i.e. alternate with single bonds), one of the bonding orbitals is raised in energy and the other lowered relative to the energy of an isolated double bond. The same applies to the antibonding orbitals. As a result, transition probability is enhanced, the wavelength of maximum absorption moves to a longer wavelength and the intensity of absorption is frequently increased.

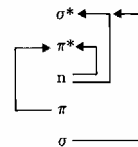
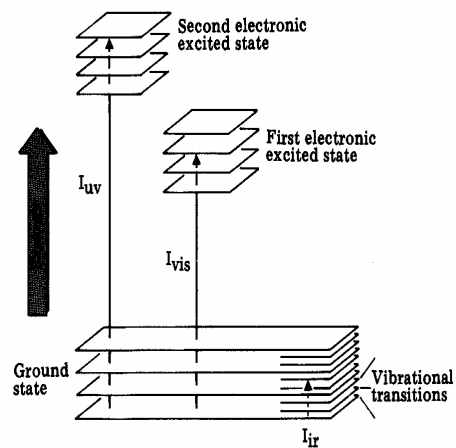

## Vibration and Rotation

The internal structure of a molecule may respond to radiant energy by more than just electronic transitions. In some molecules the bonding electrons also have natural resonant frequencies that give rise to molecular *vibration* while others exhibit a phenomenon known as *rotation*. Because the differences in energy levels associated with vibration and rotation are much smaller than those involved in electronic transitions, excitation will occur at correspondingly longer wavelengths.

Vibrational absorption is typically associated with the infrared region while the differences between energy levels related to molecular rotation are so small that far infrared or even microwave wavelengths are effective (*Fig. 6*)

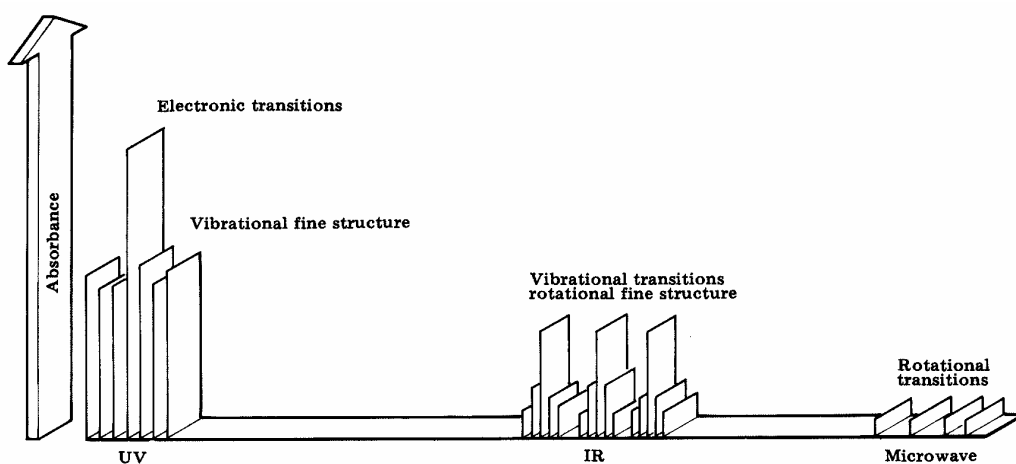
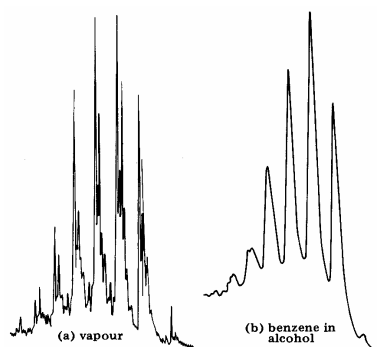

*Fig. 6* Relationship of wavelength and energy-induced transitions.

Because vibrational and rotational absorptions are primarily associated with spectral regions other than UV/Vis, it is necessary here to note only the effect on electronic absorption spectra. The principal effect is of “peak broadening”, i.e. the deviation of an observed absorption peak from the predicted shape.

For most absorbing species, especially in solution, absorption peaks do not appear as sharp lines at highly differentiated wavelengths, but rather as bands of absorption over a range of wavelengths. A principal reason is that an electronic transition is frequently accompanied by vibrational transitions between electronic levels (vibrational fine structure). In the same way each vibrational level may have associated rotational levels so that an absorption spectrum due to an electronic transition may well be a complex structure, with contributing components from vibrational and rotational absorption.

The complexity of absorption bands can frequently be demonstrated by plotting the same spectral region for the same absorbing species both in solution and as a vapour (*Fig. 7*)



*Fig. 7* UV spectrum of benzene.

## 5. Specific Absorption

Because each electron in a molecule has a unique ground state energy, and because the discrete levels to which it may jump are also unique, it follows that there will be a finite and predictable set of transitions possible for the electrons of a given molecule. Each of the transitions, or jumps, requires the absorption of a quantum of energy and if that energy is derived from electromagnetic radiation there will be a direct and permanent relationship between the wavelength of the radiation and the particular transition that it stimulates. That relationship is known as specific absorption and a plot of those points along the wavelength scale at which a given substance shows absorption 'peaks', or maxima, is called an absorption spectrum (Fig. 8).

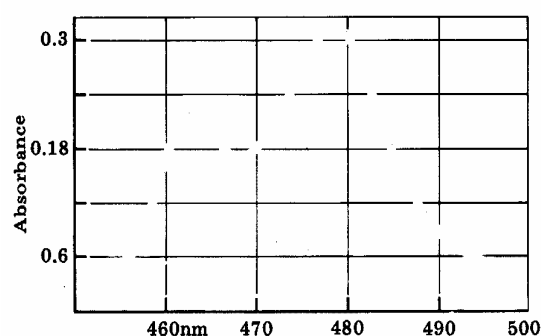

Fig. 8 Typical absorption spectrum in visible region (*Samarium Perchlorate*)

The absorption spectrum of a compound is one of its most useful physical characteristics, both as a means of identification (qualitative analysis) and of estimation (quantitative analysis). If there is absorption in the visible and that absorption occurs in the red then the substance will be seen as green/blue since red and green/blue are complementary colours (Fig. 9). [Note: Experiment 4 at the end of this book shows how complementary colours relate to absorption peaks.]

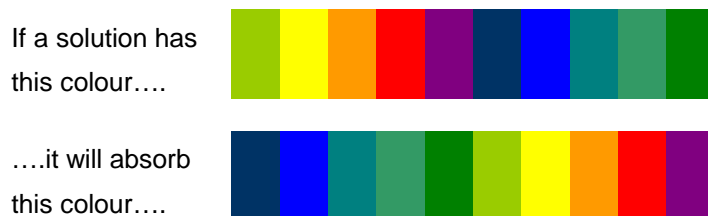
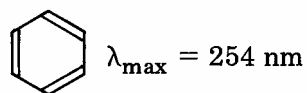

Fig.9 Complementary colours.

The chemical group most strongly influencing molecular absorption characteristics is called a chromophore. Chromophores which can be detected by UV/Vis spectrophotometers always involve a multiple bond (such as C=C, C=O or C≡N) and may be conjugated with other groups to form complex chromophores. A typical example is the benzene ring which has an absorption peak at 254 nm.



Increasingly complex chromophores move the associated absorption peak towards longer wavelengths and generally increase the absorption at the maxima.

Although the emphasis on the value of UV/Vis spectrophotometry is naturally towards organic compounds, there is a wide range of inorganic substances that lend themselves to similar methods of analysis. Species with a non-metal atom double bonded to oxygen absorb in the ultraviolet region, and there are several inorganic double-bond chromophores that show characteristic absorption peaks. In some instances, measurement of inorganic materials may demand a secondary process, such as complexation with a colour-forming reagent or oxidation - e.g. manganese (II) oxidised to manganese (VII) and measured as the  $\text{MnO}_4^-$  ion (permanganate).

## 6. Absorption and Concentration

For analytical purposes, two main propositions define the laws of light absorption.

**Note:** In this section ideal conditions are assumed throughout. The potential errors arising from scatter, reflection, fluorescence etc. are discussed in section 9.

A. *Lambert's Law.* The proportion of incident light absorbed by a transparent medium is independent of the intensity of the light (provided that there is no other physical or chemical change to the medium). Therefore successive layers of equal thickness will transmit an equal proportion of the incident energy (Fig. 10).

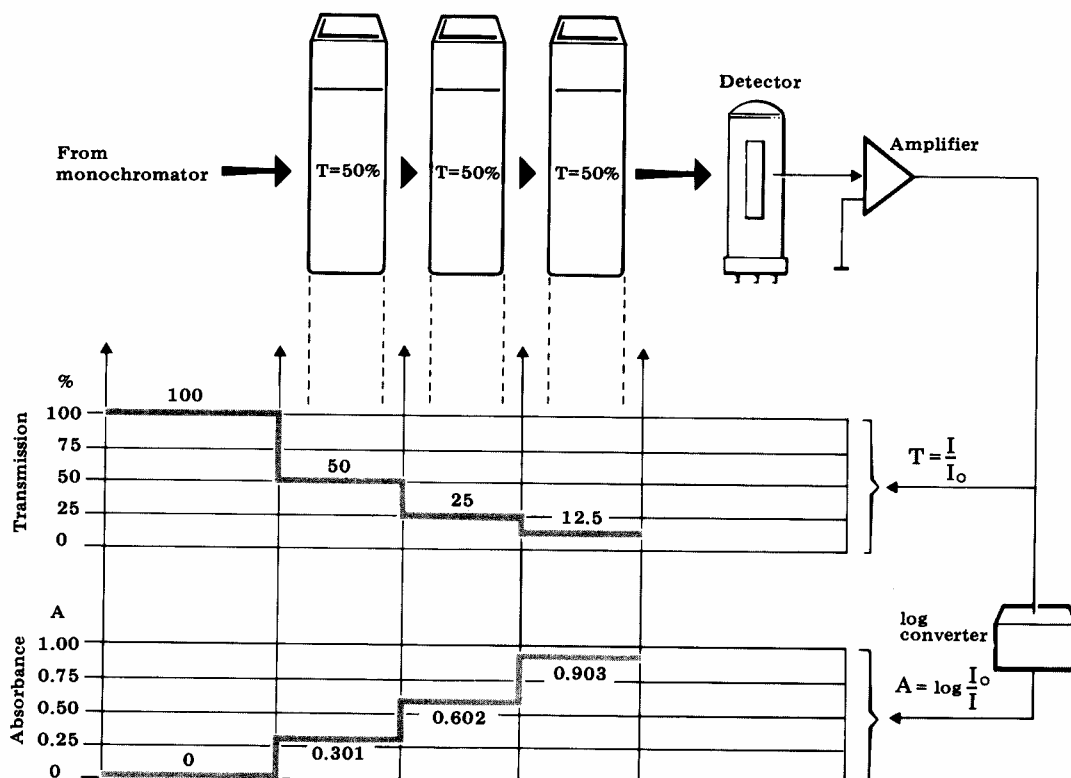

Fig. 10 Diagrammatic representation of relationship between Transmission and Absorption.

Lambert's law is expressed by

$$\frac{I}{I_0} = T$$

where  $I$  is the intensity of the transmitted light,  $I_0$  is the intensity of the incident light, and  $T$  is the Transmittance.

It is customary to express transmittance as a percentage:

$$\%T = \frac{I}{I_0} \times 100$$



B. *Beer's Law.* The absorption of light is directly proportional to both the concentration of the absorbing medium and the thickness of the medium in the light path (*Fig. 10*).

A combination of the two laws (known jointly as the Beer-Lambert Law) defines the relationship between absorbance (A) and transmittance (T).

$$A = \log \frac{I_0}{I} = \log \frac{100}{T} = \epsilon c b$$

where A is absorbance (no unit of measurement),  $\epsilon$  is molar absorptivity ( $\text{dm}^3 \text{ mol}^{-1} \text{ cm}^{-1}$ ), c is molar concentration ( $\text{mol dm}^{-3}$ ), and b is path length (cm)

It is important to note that  $\epsilon$  is a function of wavelength and so the Beer-Lambert law is true only for light of a single wavelength, or monochromatic light.

*Fig. 10* illustrates the conditions when three samples (e.g. standard solutions) having identical absorption are introduced into a beam of monochromatic light. Each of the samples is chosen so that precisely one half of the intensity of the incident radiation is transmitted ( $T = 50\%$ ).

If the intensity of the incident radiation is 100%T, then the intensity after each sample will be:

$$\begin{aligned} \text{after Sample 1} &= 1 \times 0.5 &= 50\%T \\ \text{after Sample 2} &= 50\% \times 0.5 &= 25\%T \\ \text{after Sample 3} &= 25\% \times 0.5 &= 12.5\%T \end{aligned}$$

The three samples may be considered as known concentrations of an absorbing medium and it therefore becomes possible to plot concentration against transmission. It will be found that the resultant graph is exponential, and so of limited value (*Fig. 11*).

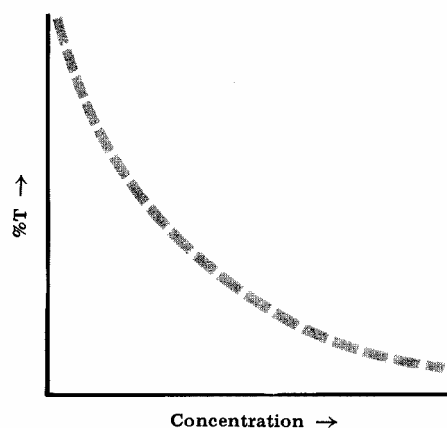

*Fig. 11* Transmission plotted against concentration.

However, providing the light is monochromatic and the Beer-Lambert law is obeyed, it becomes possible to define the process in terms of absorbance (A).

In the example above, the expression relating A to T ( $A = \log 100 / T$ ) shows that the absorbance after each sample will be:

$$\begin{aligned} \text{after Sample 1} &= 0.301 \\ \text{after Sample 2} &= 0.602 \\ \text{after Sample 3} &= 0.903 \end{aligned}$$

It can at once be seen that a plot of absorbance against concentration will be linear (*Fig. 12*). It is therefore more convenient to express results in absorbance rather than transmission when measuring unknown concentrations, since linear calibration plots will be available.

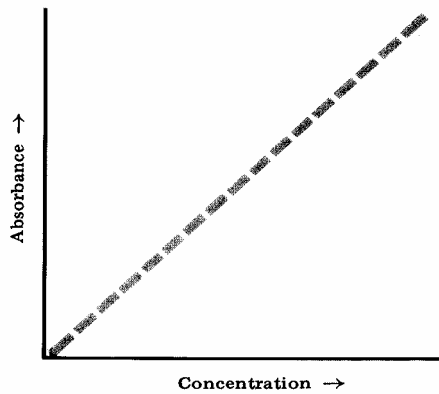

*Fig. 12 Absorbance plotted against concentration.*

An alternative to plotting calibration curves is to make use of the relationship:

$$C = k A$$

where C is the concentration of the unknown, A is the measured absorbance of the unknown, and k is a factor derived from the reference or standard solution.

To determine the factor, measure the absorbance of a standard solution of known concentration and divide the concentration by the absorbance.

$$k = \frac{\text{concentration}}{\text{absorbance}} \quad \begin{array}{l} \text{(standard)} \\ \text{(standard)} \end{array}$$

The factor k may be applied to a series of absorbance measurements on similar solutions measured in the same conditions to give results directly in concentration.

In many of today's spectrophotometers, the output electronics provide the means of entering the concentration value of the standard or the factor to the calculation so that instrument readings are directly in concentration units.

## 7. Instrumentation

The minimum requirements of an instrument to study absorption spectra (a spectrophotometer) are shown below (Fig 13):

1. a source of radiation of appropriate wavelengths.
2. a means of isolating light of a single wavelength and getting it to the sample compartment - monochromator and optical geometry.
3. a means of introducing the test sample into the light beam - sample handling.
4. a means of detecting and measuring the light intensity.

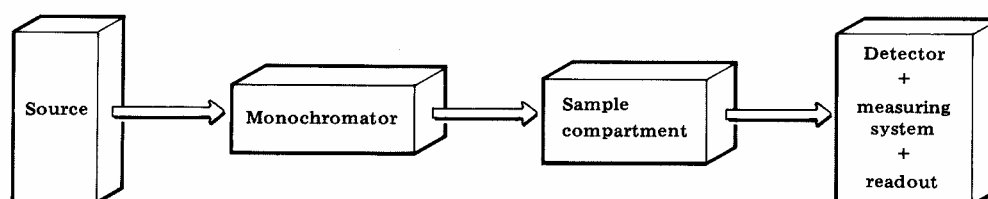

Fig. 13 Basic construction of a spectrophotometer.

### Source

The requirements are that the source should be stable during the measurement period, i.e. that the intensity of emitted radiation should not fluctuate, and that there should be adequate intensity over as large a wavelength region as possible.

Ultraviolet light is generally derived from a deuterium arc that provides emission of high intensity and adequate continuity in the 190 - 380 nm range. A quartz or silica envelope is necessary not only because of the heat generated but also to transmit the shorter wavelengths of the ultraviolet radiation. The limiting factor is normally the lower limit of atmospheric transmission at about 190 nm (Fig. 14).

Visible light is normally supplied by a tungsten lamp or, in modern systems, by a tungsten-halogen (also described as quartz-iodine) lamp which has higher relative output in the cross-over region (320 - 380 nm). The long wavelength limit is usually the cut-off of the glass or quartz envelope, normally well beyond the useful visible limit at 900 nm (Fig. 14).

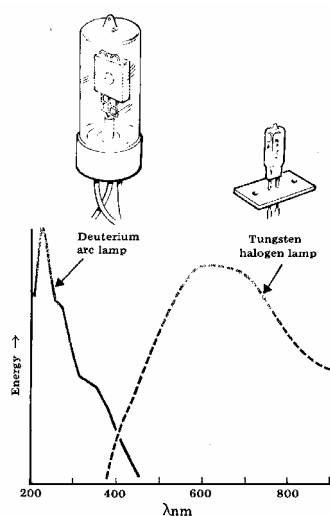

In most modern spectrophotometers the power supply arrangements, including any necessary start-up sequences for arc lamps, as well as the cross-over between sources at the appropriate wavelength, are automatic mechanical sequences. Lamps are usually supplied on pre-set focus mounts or incorporate simple adjustment mechanisms for easy replacement.

Recently, xenon lamp sources have been introduced, and these cover the UV and visible range. There is a trade off, however, because the instrumental stray light is higher and there is less energy at the far visible end. For general measurements, however, they are ideal and have the benefit of a long lifetime as they are only consumed during the actual measurement cycle ("press to read"). In addition, no cross-over wavelength is necessary.

Fig 14 UV/Vis light sources

## Monochromator

The function of a monochromator is to produce a beam of monochromatic (single wavelength) radiation that can be selected from a wide range of wavelengths. The essential components are (1) entrance slit, (2) collimating device (to produce parallel light), (3) a wavelength selection or dispersing system, (4) a focusing lens or mirror and (5) an exit slit.

Two basic methods of wavelength selection may be noted, filters and a dispersing system (e.g. a prism or diffraction grating).

### Filters

Filters of coloured glass or gelatine are the simplest form of selection, but they are severely limited in usefulness because they are restricted to the visible region and they have wide spectral bandwidths. Typical bandwidths are rarely better than 30 - 40 nm. (Note: See section 8 for a discussion of the importance of bandwidth in spectrophotometry).

Interference filters, essentially a substrate (glass normally, but may be silica) on which materials of different refractive indices have been deposited can be constructed with bandwidths of the order of 10 nm or less. However, the comparatively wide bandwidth - and therefore limited resolution - of filters, together with their inability to provide a continuous spectrum (except in special form such as wedge filters) make them inappropriate for use in routine laboratory spectrophotometry, in spite of low cost and technical simplicity.

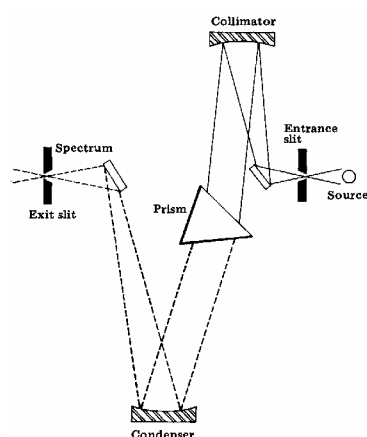

### Prisms

A prism of suitable material and geometry will provide a continuous spectrum in which the component wavelengths are separated in space. It is usual to improve the definition of the light between the source and the prism by using an entrance slit (to define the incident beam) and a collimator (to produce a parallel beam at the prism). After dispersion the spectrum is focused at the exit slit which may be scanned across the beam to isolate the required wavelength. In practice the prism is normally rotated to cause the spectrum to move across the exit slit. A typical prism monochromator is shown in Fig. 15. Reflecting components, i.e mirrors instead of lenses, are desirable in UV systems for both efficiency and cost considerations.

Fig 15 Simple prism monochromator

Prism monochromators with bandwidths in the UV/Vis of 1 nm or better are achieved without great difficulty and so performance is greatly improved compared with filter-based designs. However, there are drawbacks associated with using prisms: (1) their non-linear dispersion, (2) the temperature related characteristics of the commonly used prism materials and (3) the complicated prism drive mechanism necessary to provide a convenient wavelength control and readout.

## Diffraction Gratings

Gratings provide an alternative means of producing monochromatic light. A diffraction grating consists of a series of parallel grooves (lines) on a reflecting surface that is produced by taking a replica from a master carefully prepared using a machine or, increasingly, from one which is holographically generated. The grooves can be considered as separate mirrors from which the reflected light interacts with light reflected from neighbouring grooves to produce interference, and so to select preferentially the wavelength that is reflected when the angle of the grating to the incident beam is changed.

Among the advantages that gratings offer (compared to prisms) are better resolution, linear dispersion and therefore constant bandwidth and simpler mechanical design for wavelength selection (*Fig. 16*).

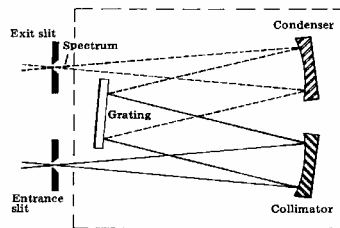

*Fig. 16* Diffraction grating monochromator.

When parallel radiation illuminates a reflecting diffraction grating, the multiple reflections from the mirror grooves will overlap and interfere with each other. If the reflected waves are in phase interference is said to be constructive and the reflected light is not affected. If the reflected waves are out of phase there is destructive interference and light of the wavelength at which such interference occurs will not be propagated.

The relationship that determines the wavelength of the reflected light is expressed by:

$$n \lambda = 2d \sin \theta$$

where  $n$  is the order (see below),  $d$  is the separation of the reflecting surfaces (or lines) and  $\theta$  is the angle of incidence of the radiation. Rotating the grating in the light beam changes  $\theta$  and so selects the wavelength reflected (*Figs. 17, 18 and 19*)

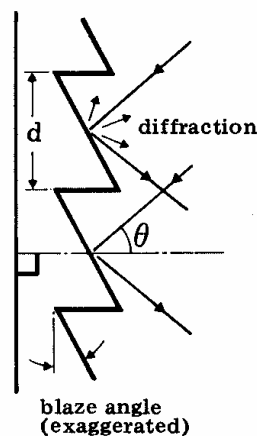

*Fig. 17* Operating principles of a reflecting diffraction grating.

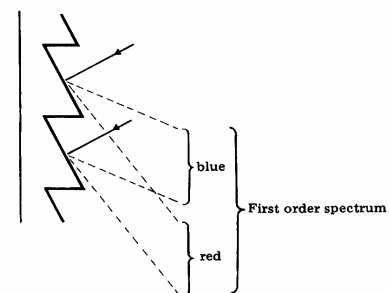

*Fig. 18* Spectral distribution after diffraction.

Two additional characteristics of gratings may be noted:

1. If wavelength  $\lambda$  is reflected for a given angle  $\theta$ , then  $\lambda/2$ ,  $\lambda/3$  and so on are also reflected at that angle. These overlapping spectra, known as second and third orders etc, can be removed with filters or with a pre-monochromator. Careful selection of the blaze angle (the angle at which the groove is cut) will peak the energy at the wavelength of the blaze, typically 250 nm for instruments of the kind under discussion.

2. Both the energy and the resolution of a grating are directly proportional to the number of lines. For maximum efficiency the line separation should be as close as possible to one wavelength and for UV/Vis gratings the line density is typically 1200 per mm.

Gratings have the following advantages over prisms:

- better resolution and energy transfer.
- linear dispersion and therefore constant bandwidth.
- less complicated wavelength drive mechanism is required.
- stray light is limited to imperfections at the grating surface.

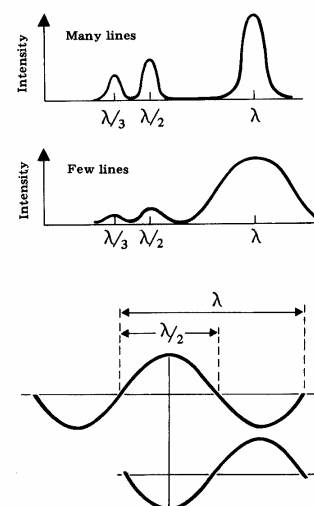

Fig 19 Schematic relationship of energy distribution and grating line density

## Optical geometry

As all absorption measurements are ratio dependent ( $I/I_0$ ), it is necessary to record a reference solution before bringing the sample under test into the light path. These measurements are done using a cuvette (matched, if possible, to that containing the test sample) in the light path filled with the appropriate solvent. The reference intensity ( $I_0$ ) varies with wavelength in a complicated multi-function way (due mainly to source energy, monochromator transmission, slit width and detector response), so it is essential, when measuring absorption, to re-measure the reference for each discrete wavelength at which measurement is to be made. All modern instruments are microprocessor based, and have the facility to store a baseline, that is 100 %T or 0 A set at each wavelength in the range, overcoming this requirement. This has allowed single beam spectrophotometers to compete on performance with the more expensive double beam instruments.

Additional advantages of microprocessor handling of the detector output are the ability to introduce component factors (e.g. concentration or molar absorption data) and to present results in alternative formats without additional manual calculation. An important consideration in some laboratories is the ability to interface with personal computers (Fig. 24), so that results can be incorporated into a laboratory information management system (LIMS) or transferred to disk for archiving or data manipulation purposes.

## Single beam optics

The development of the microprocessor has made it possible to achieve excellent results using a single beam configuration when compared to a double beam configuration; this results in greater optical and mechanical simplicity, as shown in Fig. 16. The process of comparison between reference and sample cells can be achieved with single beam instrumentation by feeding the post detector signal to a microprocessor which stores the reference data for subtraction from the sample signal prior to printing or displaying the reference corrected result (the baseline). Signal levels can be compared between different samples at one wavelength, at a series of predetermined wavelengths or, if wavelength drive is provided, a complete absorption spectrum can be obtained.

## Split (reference) beam optics

With the introduction of xenon flash lamps into spectrophotometers, the split beam configuration has become necessary; this is because the high intensity flashes from the xenon pulse lamp are not always of equal magnitude. Thus approx. 70 %, of the energy from the monochromator is passed through the sample, with the rest going to a separate feedback detector, enabling a means of taking into account drops/gains in energy via a feedback gain loop in the detector electronics. This stabilises the system, and there are no large extra cost elements involved.

## Double beam optics

Traditionally, the preferred technique was a double-beam geometry in the sample handling area (*Fig. 20*). Double-beam operation is achieved by a time-sharing system in which the light path is directed (by rotating sectional mirror or similar device) alternately through the sample and the reference cell. The wavelength dependent functions of the instrument are significantly reduced to give much improved operating characteristics by a feedback system in the reference channel that adjusts the detector gain to compensate for source and detector variations. To make full use of the potential of double beam operation it is usual to add wavelength scanning and some form of output recording: UV/Vis spectrophotometers of this type will, after initiation, produce automatically an absorption spectrum of the kind shown in *Fig. 7 or 8*.

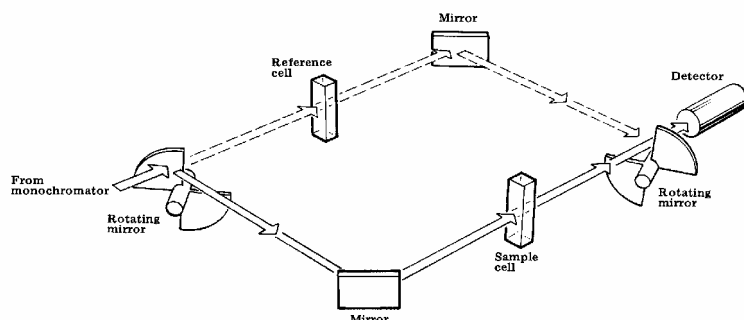

*Fig. 20 Typical double beam optics in sample area*

## Diode array optics

A fourth optical configuration is the diode array; here, light is monochromated after passing through the sample, which means that no sample compartment lid is necessary. The other major difference is that the dispersive element (grating) is fixed and does not move, as in more conventional systems.

## Sample handling

In practice, by far the greater part of all measurements will be made on samples in solution. Vapours and solids can be accommodated, but most instruments are designed with a standard cell (or cuvette) as the normal sample container. The design, construction and material of the cuvette are all important to accurate measurements as are operator practice and sample preparation.

Cuvettes are typically made of glass or UV grade silica (according to the wavelength range of interest), are fused rather than cemented (to resist the action of some solvents), and have the following characteristics:

1. optical windows (the sides through which the beam passes) are highly polished, parallel and flat
2. entrance and exit surfaces are exactly parallel and orthogonal
3. light path (distance between inner surfaces of windows) is tightly controlled.

The holder that locates the cuvette in the light beam must ensure precise and reproducible location with respect to the beam.

The most commonly used cuvette has a light pathlength of 10 mm, but longer or shorter pathlengths are useful if concentration or absorbance fall outside normal ranges without further processing - e.g. solvent extraction or dilution. Microcells are particularly useful where sample volumes are restricted: gas cells, flow cells and disposable cells are all available to extend the usefulness of the technique. A range of sample cuvettes is shown in *Fig. 21*.

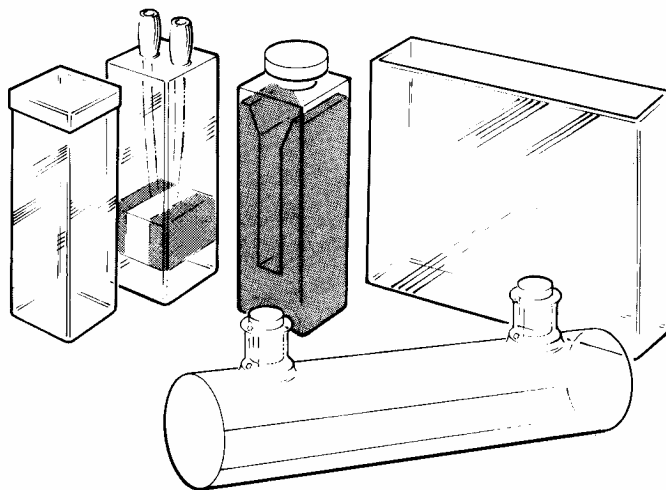

*Fig. 21 Selection of sample cuvettes.*

Disposable plastic cuvettes are used to avoid tedious washing procedures, particularly in higher throughput applications such as QC. More recently, new plastic materials that transmit down into UV have become available.

Absorption spectrophotometry is a powerful aid, both to the identification of the components of an unknown (qualitative analysis), and to the measurement of the amounts of individual components present (quantitative analysis). In qualitative work it is usually necessary to measure absorption over a range of wavelengths. Some form of wavelength scanning mechanism and a means of comparing the unknown solution with a reference are desirable features of spectrophotometers to be used for spectrum plotting. However, in many laboratories the requirement is to measure large numbers of similar samples at one or a few wavelengths only - e.g. blood samples in a busy pathology laboratory. The need to plot a complete absorption spectrum is rare. In most practical situations, therefore, single beam instrumentation is preferred for speed, convenience and simplicity of operation, and consequently reduced likelihood of operator error. Instrument requirements are usually less complex and therefore less expensive.

The technique may be assisted by a means of manually introducing a standard or reference solution into the light path at set intervals to check 0 %T and 100 %T settings. In such cases accuracy will be enhanced if the reference and sample solutions are contained in cuvettes with closely matching transmission characteristics at the wavelength of interest.



## Detectors

Of the four principal types of detectors found in spectrophotometers one, the photoconductive cell (typically a light sensitive layer, e.g. selenium, on a metal substrate) is so severely restricted in both wavelength response and sensitivity, that it is almost never found in instruments of the class under consideration. The most commonly encountered detectors are the photomultiplier, the silicon diode and the diode array.

## Photomultiplier

Photomultipliers have an internal amplification that gives them great sensitivity and a wide spectral range. Light causes emission of electrons from a photocathode which accelerate past a series of dynodes maintained at progressively increasing potentials. Electrons striking the first dynode release a secondary emission that is stronger than the original beam and so on through the dynode chain to produce a cascade effect. The electron density released by the final dynode to the anode can be many orders of magnitude greater than that from the cathode, but it remains proportional to the intensity of the incident radiation.

Two types of photomultiplier geometry may be noted: side window and end window. In most cases the end window permits the exposure to the beam of a larger cathode area and is the preferred form for higher specification instruments (Fig. 22). A single photomultiplier will provide adequate sensitivity over the whole UV/Vis region, but at some considerable cost both of the component itself and the necessary power supply and control circuitry.

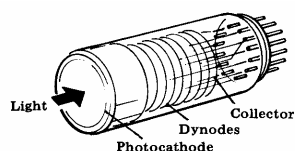

Fig. 22 End window photomultiplier.

## Silicon diode

Silicon diode detectors have performance characteristics which (when the device is integrated with an operational amplifier) compare with those of a photomultiplier, but having a wider wavelength range but less sensitivity. They are mechanically robust (being solid-state devices), and electronic benefits include reduced power supply and control circuit requirements (Fig. 23).

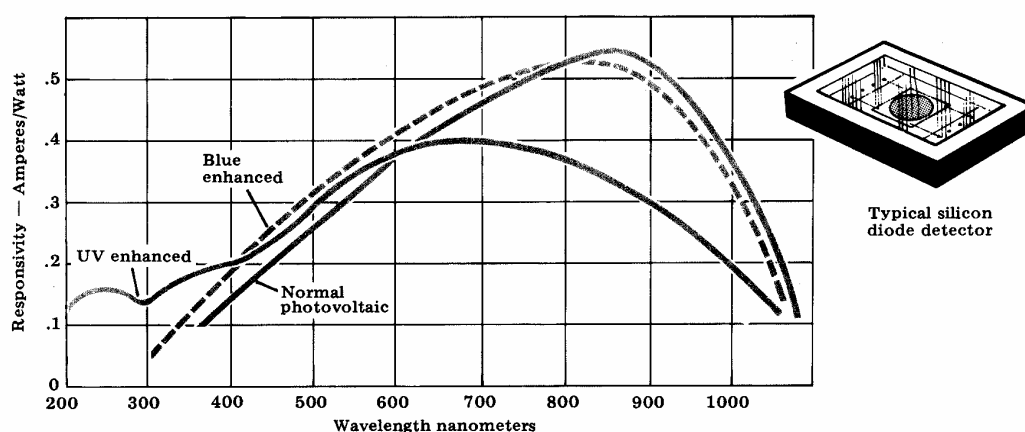

Fig. 23 Spectral response of silicon diode detectors

## Diode array

A diode array is an assembly of individual detector elements in linear or matrix form which, in a spectrophotometer, can be mounted so that the complete spectrum is focused on to an array of appropriate size. No wavelength change mechanism is required and output presentation is virtually instantaneous. Resolution, however, is limited by the physical size of individual detector elements (typically  $> 2$  nm) and wavelength range is usually limited to about 1 octave (200-400nm, 300-600nm, 400-800nm). This is because in a diode array instrument, it is difficult to introduce filters to mitigate the effects of stray light from the second order spectrum.

## Measuring Systems

The primary function of a spectrophotometer ends with the provision of a signal (normally an electrical voltage) that is proportional to the absorption by a sample at a given wavelength. The signal handling and measuring systems can be as simple as an amplifier and a meter or as elaborate as a personal computer and printer, depending on the application.

In simplest form, a meter will serve either to indicate the absolute value of the output signal, or in some instances, the null point in a back-off circuit. Digital readouts (LED or LCD) are favoured for clarity and lack of ambiguity and may be linked with a microprocessor such that readout is in any preferred terms - directly in concentration units for example. Chart (or other) recorders can be used with instruments equipped with wavelength scanning systems to provide directly an absorption spectrum. They are also useful in the study of reaction rates where the requirement may be to plot absorption against time at a fixed wavelength.

A block diagram of the post detector electronic handling and of the integrated output and drive systems of a modern sophisticated single beam spectrophotometer, all controlled via a single microprocessor, is shown in . Fig. 24.

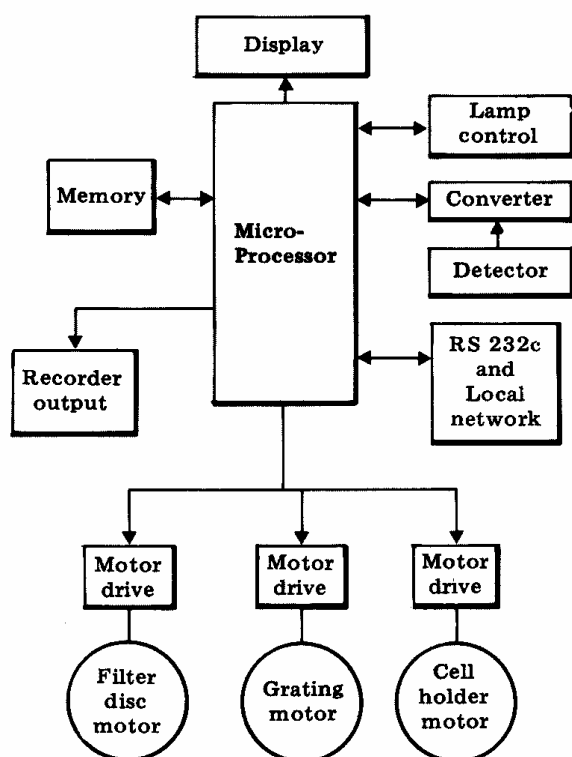

Once the operator has defined the parameters (e.g. wavelength, output mode and relevant computing factors) the system will ensure the correct and optimum combination of all the variables available. Selection of source and detector are automatically determined, any filters (e.g. order suppressing filters) or other components will be introduced into the optical train at appropriate points and sample and reference cells correctly managed in the sample area. Output in the required terms (transmittance, absorbance, concentration etc.) will be presented and the relevant sample identified.

Secondary routines such as wavelength calibration and other self-tests may be available on demand and interfacing with external computers or other instrumentation - e.g. automatic sampling devices - is easy.

Fig 24 Block diagram of a microprocessor controlled spectrophotometer

## 8. Good operating practice

The good housekeeping routines normal to any analytical laboratory are equally essential in the preparation of samples for spectrophotometric assays. The cleanliness of all materials and equipment, especially the sample cuvettes, is mandatory, as are weighing and volumetric accuracy. Temperature variations can be a source of significant error too.

It has already been pointed out that ideally the sample and reference cuvettes should be optically identical and their orientation in the light path should be carefully controlled; this is particularly the case when using a double beam spectrophotometer. Most equipment manufacturers will supply (to special order) cells with transmission characteristics matched to 1% or better over a defined wavelength range. In summary, it should be noted that the surface finish and parallelism of cuvette windows are more likely to introduce errors than pathlength variations.

### **Preferred absorption range**

The ability of a spectrophotometer to measure accurately throughout its absorption range is impaired by a number of factors, chief of which is the inherent noise in the detector. It can be shown that instruments equipped with photo-emissive detectors (phototube or photomultiplier) have minimum relative error when absorbance = 0.86 (13.5%T); for photoconductive detectors the equivalent value is 0.43.

In practice the error will not be significant for any absorbance between 0.8 and 1.5A, except where light levels are low - e.g. at the extreme limits of any of the components of the system. If it is required to adjust the sample to bring absorbance within the preferred range, it is normally better to change the sample pathlength rather than the concentration, e.g. by diluting.

Note that spectrophotometers equipped with silicon diode detectors do not suffer from this limitation. In such instruments performance limits are usually dependent on stray light (see below) and a quality system will measure absorbance up to 3A with accuracy and reliability.

### **Absorbance Measurement**

In practice, the unwanted effects of spectral bandwidth on peak absorbance measurement can be eliminated by constructing a set of calibration curves at known concentrations. Providing Beer's law is obeyed, a plot of concentration against absorbance at a given wavelength will yield a straight line from which unknown concentrations can be accurately determined if absorbance is measured under similar instrument conditions. If the measuring system of the spectrophotometer is microprocessor-based, relevant data or programmes can be entered or kept in memory. Direct readout in concentration is made easy. [Note: *Experiment 2 at the end of this book shows how to construct concentration curves.*]

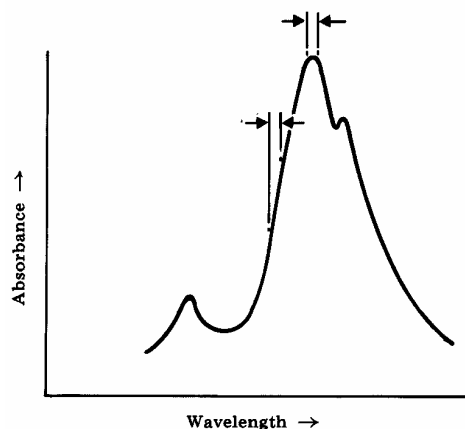

The importance of measuring absorbance precisely at the wavelength of an absorption peak, i.e. at  $\lambda_{\max}$ , is demonstrated in Fig 25. In the hypothetical case illustrated, any wavelength setting within the narrow band indicated would have no significant effect on absorbance measured at the peak. However, the same band of wavelengths displaced to shorter wavelength would introduce the possibility of major error, depending on the precise point within the band at which the measurement was taken. Errors due to either wavelength setting or instrument calibration will be at a minimum when measurements are made at the wavelength of maximum absorption. [Note: *Experiment 1 at the end of this book shows how to measure both absorbance at  $\lambda_{\max}$  and natural bandwidth.*]

Fig. 25 Importance of measurement at  $\lambda_{\max}$

### **Solvent selection**

A common characteristic of the wide range of solvents available is the rapid fall of transmission towards the short wavelength limits. Care must be taken when working below (say) 250 nm that solvent absorption is not so high that the incremental absorption due to the sample is small compared to total absorption. The problem is exacerbated in the presence of stray light, but it may be noted here that the effects are reduced at lower absorbance levels.

## 9. Sources of error

There has been an increase in laboratory requirements to conform with Good Laboratory Practice (GLP) techniques. These require that results obtained can be traced back to an instrument and that the instrument can be proved to be working correctly, for validation purposes. Instrument performance criteria for spectrophotometers have been defined by the Pharmacopoeia as being spectral bandwidth, stray light, absorbance accuracy and wavelength accuracy, and it is therefore important to check these potential sources of error periodically. Modern instruments in the mid to upper price bracket often have GLP self diagnostic tests as part of the calibration procedure, accompanied by a print out of these results.

### *Instrument related sources of error*

#### Spectral bandwidth and slit width

The resolution of a spectrophotometer - the minimum separation between narrow absorption bands that can be observed - is usually limited by the spectral purity and intensity of the monochromator light output and the detector sensitivity at that wavelength.

In some (older) instruments the control of the energy level reaching the detector is achieved by adjusting the aperture of the slit at the monochromator exit. As the exit slit defines the spectral bandwidth (the range of wavelength, *Fig. 26*) at the detector, it is important to realise that both photometric accuracy and wavelength accuracy may be affected. In general, narrower slit widths will reduce error providing the overall energy level remains adequate and electronic noise levels are not significant. Most instruments using diffraction gratings take advantage of the linear dispersion and provide fixed slit widths to give known and controlled bandwidth at the exit slit of the monochromator. More than one slit width may be available to give the user a means of trading energy against spectral sensitivity.

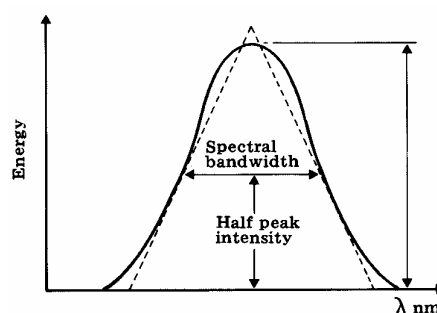
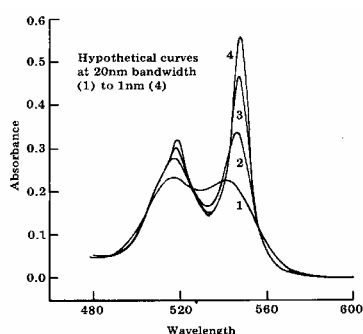

*Fig.26 Spectral bandwidth.*

The total energy at the exit slit of a monochromator at wavelength  $\lambda$  may be assumed to have a triangular function as shown in *Fig. 26*. The spectral bandwidth for a given slit width is the band of wavelength that corresponds to the half-peak intensity. A well defined absorption peak for a specific compound has a similar triangular function and can be assigned a natural bandwidth (assuming infinite resolution), at half-peak height, similar to the definition of spectral bandwidth.

The ratio of spectral bandwidth to natural bandwidth is a determining factor in absorption measurement. As the ratio of the spectral bandwidth to natural bandwidth increases, the deviation of observed absorbance from true absorbance will be greater. The natural bandwidth of most commonly encountered compounds in UV/Vis work, particularly bio-molecules in the Life Sciences, lie within the range 5 - 50 nm. Thus a spectrophotometer with a fixed bandwidth of 2 - 6 nm is ideal for bio-molecule measurement, since there is no spectral fine detail. A narrower bandwidth is required for measurements involving rare earth and transition metal complexes and conjugated organic species, where critical fine detail may be present.

A diagrammatic representation of an absorbing species measured at progressively increasing spectral bandwidths is shown in *Fig. 27*. As bandwidth increases beyond a certain value separation of the two bands is less well defined, the apparent absorbance at the maxima decreases and the observed bandwidth of the peaks increases.



*Fig. 27 Typical absorption peaks plotted at varying spectral bandwidths.*

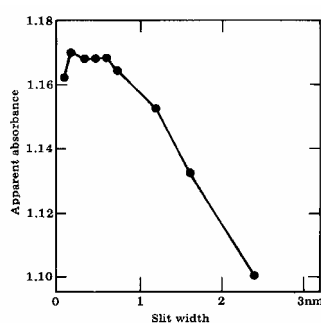

*Fig. 28 Effect of slit width on observed absorbance at  $\lambda$  max.*

Where it is necessary to determine accurately the absorbance at  $\lambda_{\max}$ , it may be desirable first to plot apparent absorbance against slit width; *Fig. 28* shows that slit widths greater than about 0.75 mm may introduce significant error into the measurement of the absorbance concerned.

## Stray Light

Much the most important instrument-related source of error is *stray light* - i.e. radiation emerging from the monochromator of all wavelengths other than the bandwidth at the selected wavelength. Stray light may originate from imperfections in the dispersing element or in other optical surfaces, from diffraction effects and other optical aberrations or from damaged or worn components. Care must also be taken to eliminate extraneous light, e.g. light leaks at cell compartment or other mechanical boundaries.

Stray light will cause apparent negative deviations from Beer's law (*Fig. 29*) and a level of 0.1% stray light at any wavelength will prevent accurate absorption measurements of greater than 3A. [*Note: Experiment 3 at the end of this book describes how to measure stray light.*]

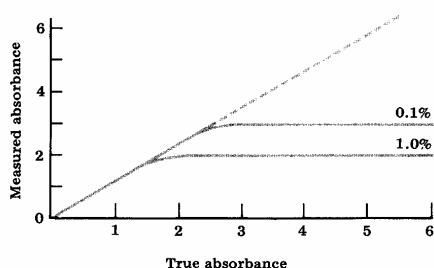

*Fig. 29 Limiting value of stray light*

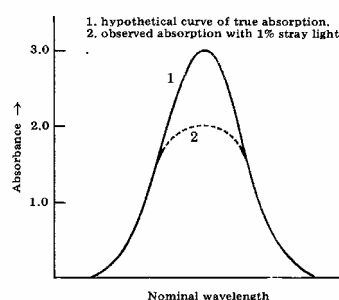

*Fig. 30 Effect of stray light on observed peak height*

The primary effect of stray light, however, is to reduce the observed peak height (*Fig. 30*). Where absorbance is high (e.g. at an absorption peak) or where instrument sensitivity is low (e.g. at the wavelength limits or near 190 nm where atmospheric oxygen absorbs strongly), the errors introduced by stray light will be relatively enhanced.

## Absorbance Accuracy

The photodetector systems of most modern instruments are linear to less than 1 % by design. Hence the only factor which has any significant effect on absorbance accuracy is stray light, described above.

## Wavelength Accuracy

The effects of wavelength inaccuracies are most noticeable when measurements are taken on the side of an absorbance peak, and it is prudent therefore to measure, wherever possible, at the absorbance maximum where the rate of change is at a minimum. In some instances, such as the A<sub>260</sub> / A<sub>280</sub> ratio used in assessing the purity of nucleic acid preparations, this is not possible and care must be taken in the interpretation of results, especially if the solutions are dilute

## Noise

Problems associated with electronic noise in the detector have been mentioned earlier. There is also the noise element associated with the random fluctuations of the photon beam reaching the detector which may be apparent in the amplifier output, especially where beam energy is low. Noise problems may be reduced by integration with respect to time or by storage and enhancement, techniques to which microprocessors are particularly suited.

## Non-instrument sources of error

Since many modern laboratories have standard operating procedures for their routine analyses, non-instrumental errors most commonly derive from the nature of the solution to be examined. To physical conditions (such as the effects of temperature or pressure) must be added such problems as multi-component mixtures where more than one constituent absorbs at a wavelength of interest. Absorbance in these conditions is additive and a Beer's law plot for one component may no longer be possible. However, it is normally possible to take readings at several wavelengths and to construct a set of simultaneous equations. The number of absorbances measured at discrete wavelengths must equal the number of components in the mixture. Providing the absorption coefficients of the components are known for each of the wavelengths measured, the equations can be solved algebraically. A personal computer interfaced to the spectrophotometer is well suited to data reduction routines of this kind, although some instruments do have this facility as part of its microprocessor based software.

The several processes that may occur when a beam of radiation meets a cell containing a solution are shown in *Fig. 31*. Total attenuation (i.e. the ratio of  $I$  to  $I_0$ ) may include components from

- (1) reflection of air/cell and solution/cell interfaces,
- (2) scattering by any suspended particles, and
- (3) absorption by the solution.

There may be an additional fluorescence component as a result of absorbed energy being re-emitted at a different (longer) wavelength from that of the incident radiation.

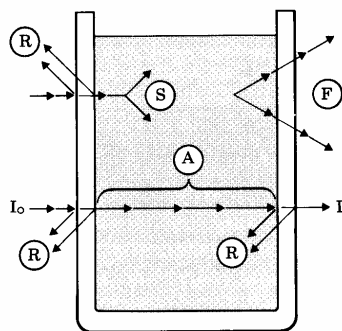

$R$  = Reflection  $S$  = Scatter  $A$  = Absorption  
 $F$  = Fluorescence.

$R$  = Reflection  $S$  = Scatter  $A$  = Absorption  $F$  = Fluorescence.

*Fig. 31* Components of total attenuation process

For all practical purposes, the effects of reflection and scattering are restricted to less than significant levels by the use of quality sample cells, matched where possible and by careful sample handling practice. Fluorescence effects may be reduced by chemical inhibition, or by appropriate cut-off filters.

## 10. Experiments

The simple experiments that follow are designed to illustrate some of the principles introduced in this booklet, and can be carried out using commonly available chemicals and apparatus. They have been designed to be appropriate for most commercially available spectrophotometers, but in all cases the manufacturer's recommendations for correct instrumental measuring procedures should be closely observed.

Although the experiments specify the use of cuvettes, test tubes can equally well be used to contain the sample. However, there may be adverse optical effects and the nominal pathlength may not be controlled as tightly as for cuvettes; accuracy may be affected.

### Potassium Dichromate stock solution

Potassium dichromate will be used in the majority of the experiments. It will be convenient to make a stock solution as follows:

1. Weigh out approximately 0.93g of potassium dichromate ( $K_2Cr_2O_7$ ) and record the weight accurately.
2. Put the weighed dichromate into a 1 litre volumetric flask and add 100 ml of 0.1 N sulphuric acid. Make up to 1 litre with distilled water, shaking the flask all the time.
3. Calculate the precise concentration by dividing the exact weight of dichromate used (recorded in 1 above) by 294.2 (the relative molecular mass of potassium dichromate).

*Use the precise weight recorded - in this example assumed to be 0.93g.*

$$\frac{0.93}{294.2} = 0.0031611$$

The concentration of the stock solution would in this case be  $3.16 \times 10^{-3}$  mol litre<sup>-1</sup>.

4. Make a series of dilutions of the stock solution as follows:

1 part of stock solution to 9 parts of distilled water,  
3 parts of stock solution to 7 parts of distilled water,  
5 parts of stock solution to 5 parts of distilled water,  
7 parts of stock solution to 3 parts of distilled water,  
9 parts of stock solution to 1 part of distilled water.

Calculate the concentrations of all dilutions and record them.

### Apparatus required

#### *For weighing*

A balance accurate to at least  $\pm 0.001$  g, spatulas, weighing boats, etc.

#### *For measuring volumes ('B' grade equipment is adequate)*

1 litre volumetric flask

either (a) a range of volumetric flasks and pipettes

or (b) two 25 ml burettes or 10 ml graduated pipettes together with glass sample containers (preferably sealed).

#### *Other equipment*

A spectrophotometer capable of measuring absorbance and transmission in the range 325 to 900 nm, beakers or conical flasks for distilled water, wash bottle and supply of distilled water, pipette filler bulb, graph paper.

### Chemicals required (general purpose reagent grade)

Potassium dichromate  $K_2Cr_2O_7$

Sodium nitrite  $NaNO_2$ ,

Dilute sulphuric acid (0.1 N)  $H_2SO_4$

As with all chemicals, care must be taken when handling the above.

Any other chemicals that have a visible colour in aqueous solution, e.g. copper sulphate, cobalt chloride, indicator dyes or food colourings.

## EXPERIMENT 1 - Calculation of absorbance at $\lambda$ max, and measurement of natural bandwidth.

1. Put approximately 3 ml of the 1 : 9 dilution in a 10 mm cuvette. The concentration will be approximately  $3.16 \times 10^{-4} \text{ mol}^{-1}$
  2. Set the spectrophotometer wavelength to 325 nm and with nothing in the spectrophotometer light path (or with a cuvette containing distilled water) set the instrument reference level.
  3. Place the cuvette containing the prepared dilution in the sample compartment. Record the absorbance.
  4. Repeat steps 2 and 3 at wavelength increments of 10 nm up to 405 nm and record absorbance at each wavelength setting.
  5. Plot the results as absorbance against wavelength.
  6. To determine more precisely the wavelength of maximum absorbance repeat the measurements from 340 to 360 nm at increments of 5 nm.
  7. From the graph note the wavelength of maximum absorbance for this solution.
- A. Calculate the molar absorptivity of potassium dichromate, at the wavelength of maximum absorption, using the equation

$$E = \frac{A}{c b}$$

The result will be approximately  $3150 \text{ l mol}^{-1} \text{ cm}^{-1}$  at  $\lambda$  max 350 nm.

Three parameters have now been determined for the sample under test;

- i) molar mass
  - ii) concentration in mols/litre
  - iii) molar absorptivity.
- B. Project the slopes of the peak at  $\lambda$  max to the base line to give a triangular figure. Estimate the natural bandwidth of this peak by measuring the width of the triangle (in nm from the wavelength axis) at half its height (Refer to *Fig. 25*).

## EXPERIMENT 2 - Construction of concentration plots

1. Set the wavelength of the spectrophotometer to  $\lambda$  max as determined in Experiment 1, and record both absorption and transmission of all the dilutions of the stock solution of potassium dichromate prepared earlier.
2. On the same graph paper prepare two plots, one of absorbance against concentration and one of transmission against concentration.

Note that the absorbance plot is linear to about 2A and that the transmission plot is exponential.

Suggest reasons for the flattening of the absorbance plot at values greater than about 2A; or more, depending on the spectrophotometer used (Refer to *Fig. 30*).

Concentration plots similar to those just constructed may be used to find the concentration of an unknown sample of the same solution (it is customary to plot only the absorbance values against concentration, not transmission.)

If the measured absorbance of the unknown lies outside the linear section of the plot, the reading may be brought within the linear section either by using a cuvette of shorter pathlength or by diluting the sample by a known factor. If a shorter pathlength is chosen the observed absorbance must be multiplied by a factor related to the ratio of the two pathlengths, e.g. if the curve is based on 10 mm cells and a 5 mm cell is used, multiply by 2. If the dilution method is selected, calculate the concentration by multiplying the absorbance by the same factor as the dilution and then read the value from the plot prepared as described above.



### **EXPERIMENT 3 - Testing for Stray Light**

1. Make up a solution of sodium nitrite ( $\text{NaNO}_2$ ) in distilled water at a concentration of  $50 \text{ g l}^{-1}$  (e.g. 5g in 100 ml) and fill a 10 mm cuvette.
2. Set the wavelength of the spectrophotometer to 340 nm and set the reference (100%T) with nothing in the sample compartment (or with a cuvette filled with distilled water).
3. Put the cuvette containing the sodium nitrite solution in the sample compartment of the spectrophotometer.

Sodium nitrite acts as a blocking filter, absorbing all incident radiation at the wavelength selected, but transmitting virtually all of the radiation at longer wavelengths. Therefore any transmission recorded at 340 nm will be a direct measurement of the stray light of the instrument.

The value should be in accordance with the manufacturer's specification; for some instruments this could be  $< 0.05 \%$ .

### **EXPERIMENT 4 - Demonstration of visible colours and spectral sensitivity of the human eye.**

For this experiment a light pipe as well as the following will be required: copper sulphate, potassium dichromate, some indicator dyes e.g. bromophenol blue, congo red.

1. Make up a solution of each substance in distilled water, such that the concentration is sufficient for colour to be seen against a white background. Concentration should not be too strong.
2. Forecast the wavelength at which each solution will absorb. [Note that the colour observed will be complementary to the colour absorbed.] Make a forecast for each solution prepared (Refer to *Fig 9*).
3. Measure the absorbance of each solution for 100 nm around the forecast wavelength (i.e. forecast  $\lambda \pm 50 \text{ nm}$ ) at intervals of 10 nm and plot the results.
4. Determine from the plots the regions of absorption for each solution and compare how closely they match the forecasts made in 2 above.
5. Note the colour of solution that corresponds to the absorption peak recorded.
6. Using a light pipe, examine the colour of the light in the sample compartment at the wavelength of maximum absorption for each solution.
7. With the light pipe in position, use the wavelength control to move throughout the range of the instrument and note the point at either end when no colour change can be seen. This will occur in both the red and blue regions of the spectrum.

This provides an indication of the spectral sensitivity of the observers' eye; note that this will vary between individuals.